

DESIGN NOTES

Low Parts Count DC/DC Converter Circuit With 3.3V and 5V Outputs – Design Note 69

Ron Vinsant

This Design Note describes a simple low cost dual output step-down converter circuit based on the LT1076 five terminal switching regulator.

Performance

Input voltages can range from 8V to 30V. The load range on the 5V is 0.05A to 0.5A while the 3.3V load range is 0.1A to 1A. The circuit is self-protecting under no load conditions; it will “burp” in the same fashion as many off-line flyback power supplies.

Output voltage regulation is excellent. Over all load and line conditions, including cross regulation, the 3.3V output varies from 3.25V to 3.27V. The 5V output varies from 4.81V to 5.19V under the same conditions.

In a typical application of 0.5A on the 3.3V and 0.25A on the 5V, efficiency is typically 76%. With an input voltage of 30V and full load, the efficiency drops to 66%. In normal operating regions efficiency is always better than 70%.

The 5V ripple is less than 75mV and the 3.3V ripple less than 50mV over all line and load conditions.

This design can help save both parts and cost by the elimination of a second regulator. Only a few additional

parts are required to make the second output. They are: two resistors, a Schottky diode, a small ceramic capacitor and a filter electrolytic; only 5 additional components! The normal single winding inductor has one small winding added to create the additional output.

The circuit has been built in our lab and has only been evaluated for room temperature performance. No stability analysis has been done.

Inductor

The inductor is based on a EP-13 ferrite core which is available from a number of vendors. In our breadboard we used a Ferroxcube core in 3C81 material gapped to 6 mils (center gap). The 3.3V winding is 22 turns of #25 AWG while the 5V winding is 13 turns of #28 AWG. Any magnetics vendor should be able to wind this device. The inductor has only a 14°C temperature rise. Coiltronics at (305) 781-8900, or Hurricane Labs at (801) 635-2003 can supply this inductor off the shelf.

Capacitors

Ripple current in the output capacitors C2 and C3 is 250mA_{RMS} total with the input voltage at 30V and maximum load on the two outputs.

The input capacitor (C1), which undergoes higher stress, has a ripple current of 830mA maximum at 14V input and maximum load.

The input and output capacitors have been chosen primarily for ESR, not for voltage. The 50V rating of the capacitors is not due to stress from the circuit but from the fact that the lowest ESR for a particular can size occurs at 50V, in this series of capacitors, from this specific manufacturer.

The capacitors in the frequency compensation network should be at least X7R ceramic, never Z5U, and if broad temperature operation is expected, polyester or polycarbonate film caps should be used.

Performance Table

V _{IN}	V _{OUT} , OUTPUT 1 (5V) @ I _{OUT} = 0.4A	V _{OUT} , OUTPUT 2 (3.3V) @ I _{OUT} = 1A
8V	4.81	3.26
30V	5.07	3.26
V _{IN}	V _{OUT} , OUTPUT 1 (5V) @ I _{OUT} = 0.05A	V _{OUT} , OUTPUT 2 (3.3V) @ I _{OUT} = 1A
8V	5.14	3.25
30V	5.19	3.25
V _{IN}	V _{OUT} , OUTPUT 1 (5V) @ I _{OUT} = 0.4A	V _{OUT} , OUTPUT 2 (3.3V) @ I _{OUT} = 0.1A
8V	4.81	3.26
30V	5.02	3.27
V _{IN}	V _{OUT} , OUTPUT 1 (5V) @ I _{OUT} = 0.05A	V _{OUT} , OUTPUT 2 (3.3V) @ I _{OUT} = 0.1A
8V	5.07	3.26
30V	5.11	3.26

Layout

In order to achieve proper performance it is important to lay out the circuit as shown in Figure 1. Use a single point ground at the output of the converter as shown. The term "short" indicates that the trace should be as short as possible between the two points shown. These traces should have a minimum width of 0.2" in 2 oz. copper for a length of less than 1.5". Traces longer than this should be avoided on heavier lines of the schematic.

Heat Sinking

Any heat sink of 30°C/W or lower will keep the LT1076 at an acceptable temperature up to a 70°C ambient. See the LT1076 data sheet for further information.

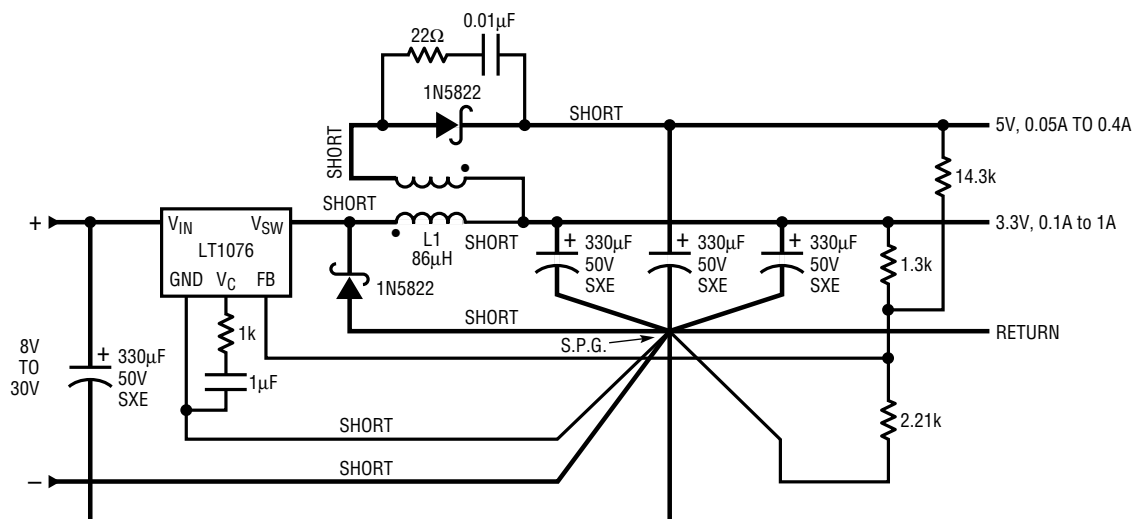

S.P.G. SINGLE POINT GROUND, (STAR GROUND)
DARK LINES INDICATE HIGH CURRENT PATHS (SEE TEXT)
L1 = HURRICANE LABS HL8685
= COILTRONICS CTX01-11959
ALL ELECTROLYTIC CAPACITORS, UNITED CHEMICON SXE SERIES

Figure 1. 3.3V to 5V Dual Output DC/DC Converter

For literature on our DC/DC Converters,
call (800) 637-5545. For applications help,
call (408) 432-1900, Ext. 456